

Adhered TPO Membrane - Cover Board (MA) - Concrete Deck (New or Tear-Off)

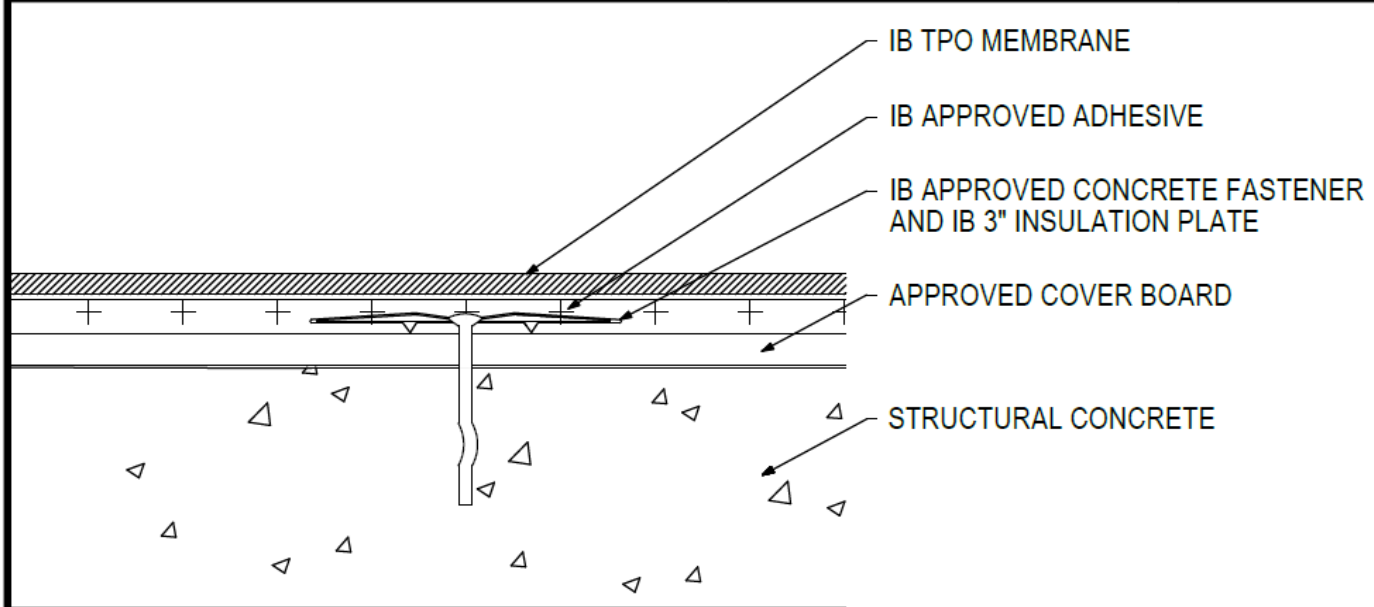

Deck Type	Cover Board			IB Membrane Securement**
	Type ^{1,2}	Attachment	Fastener/Plate***	Attachment ³
Structural Concrete	Approved Cover Board	8 per 4' x 8' (1 per 4.0 sq. ft.)	DekSpike, or CD-10, 3" IB Insulation Plate	IB Approved Adhesive
Structural Concrete	Approved Cover Board	10 per 4' x 8' (1 per 3.2 sq. ft.)	DekSpike, or CD-10, 3" IB Insulation Plate	IB Approved Adhesive
Structural Concrete	Approved Cover Board	12 per 4' x 8' (1 per 2.67 sq. ft.)	DekSpike, or CD-10, 3" IB Insulation Plate	IB Approved Adhesive
Structural Concrete	Approved Cover Board	16 per 4' x 8' (1 per 2.0 sq. ft.)	DekSpike, or CD-10, 3" IB Insulation Plate	IB Approved Adhesive
Structural Concrete	Approved Cover Board	20 per 4' x 8' (1 per 1.6 sq. ft.)	DekSpike, or CD-10, 3" IB Insulation Plate	IB Approved Adhesive
Structural Concrete	Approved Cover Board	24 per 4' x 8' (1 per 1.3 sq. ft.)	DekSpike, or CD-10, 3" IB Insulation Plate	IB Approved Adhesive

¹Approved Cover Board: DensDeck Prime, DensDeck ProFast Prime, DensDeck StormX Prime, Securock Ultralight Coated Glass-Mat, Securock Gypsum Fiber Board, or DEXcell FA Glass Mat Roof Board, minimum 1/4" thickness; or minimum 7/16" DEXcell Cement Roof Board; or minimum 1/2" IB HD ISO-J, or 1/2" IB Recovery Energy Board III-J.

²The use of some IB Approved Cover Boards may not achieve UL Classification.

³Approved Adhesive: IB TPO Water Based Adhesive, IB TPO Bonding Adhesive, IB TPO LVOC Adhesive, IB TPO CA LVOC Adhesive, or IB TPO Spray Contact Adhesive.

Note: IB TPO Bonding Adhesive, IB TPO LVIC Adhesive and IB TPO CA LVOC Adhesive cannot be used with IB TPO FB Membranes.

System Uplift Note(s): **Refer to applicable Approval Guide for System Code and/or FM Approvals Information. ***Refer to Substrate Resistance Table for required pull-out values.

For additional information about IB Roof Systems requirements, recommendations, installation details, approvals, and limitations for the above assemblies, please refer to the latest edition of the IB Roof Systems Specifications Manual. For Technical Services please contact IB Technical Department at 800-426-1626.

Membranes:		Membrane Color:			Warranty Length**				Warranty Type**	
IB TPO SM 60 Mil		White*	Gray	Tan	10 Year	15 Year	20 Year		Contractor Warranty Only	
IB TPO SM 80 Mil		White*	Gray	Tan	15 Year	20 Year	25 Year		Total Systems - No Dollar Limit (TSW)	
IB TPO FB 115 Mil		White*			10 Year	15 Year	20 Year		Warranty Plus (WP)	
IB TPO FB 135 Mil		White*			15 Year	20 Year	25 Year		Commercial Limited Material Warranty (CLMW)	
									Residential Limited Material Warranty (RLMW)	

*Meets CRRC, Title 24, LEED (SRI)

**Refer to Warranty Selection Guide for Warranty Riders, Term Length Limitations, and eligibility requirements of the IB Warranty Program

Submitted By:		Project Name:	
Company Name:		Address:	
Email/Phone:		City/State:	