

Adhered TPO Membrane (SP) - Existing Roof (SA) - Steel Deck (Recover)

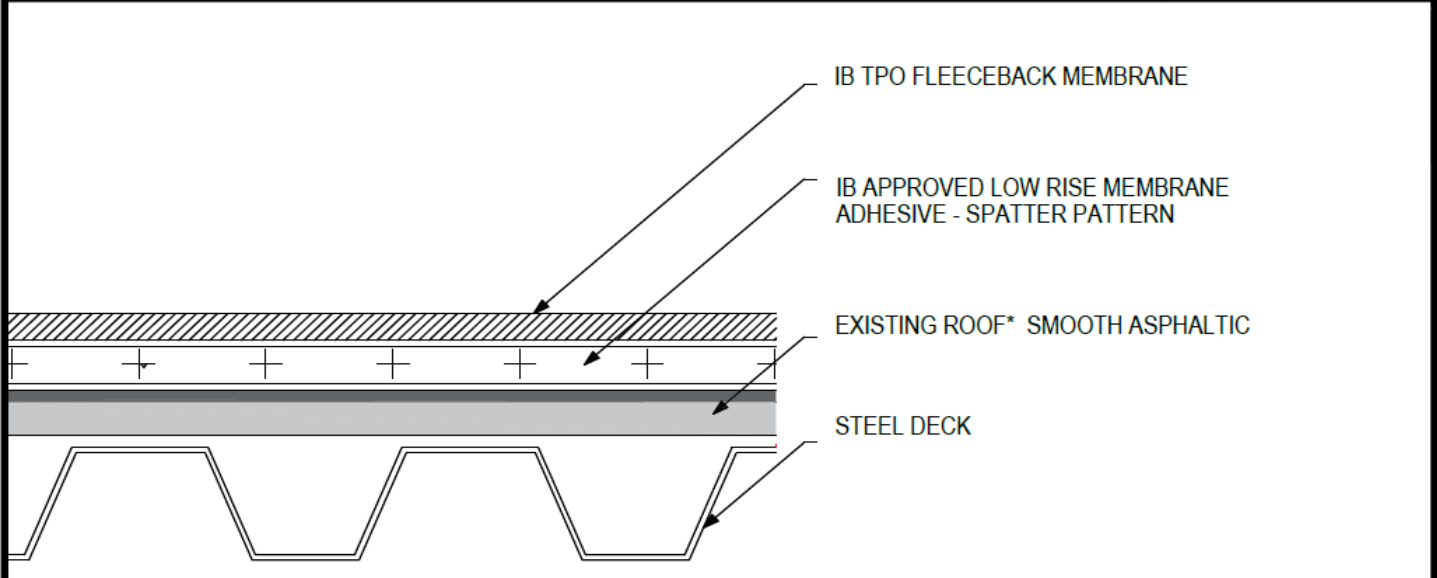

Deck Type	IB TPO Fleeceback Membrane (over Existing Smooth Asphaltic Roof)	
	Type ¹	Attachment ^{2,3}
Min. 22 ga. Type B Grade 33 Steel	Existing Smooth Asphaltic Roof	IB Approved Low Rise Membrane Adhesive
Min. 22 ga. Type B Grade 80 Steel	Existing Smooth Asphaltic Roof	IB Approved Low Rise Membrane Adhesive

¹Existing Roof: APP or SBS modified bitumen, smooth or granule surfaced asphaltic built-up roof only.
²Approved Low Rise Membrane Adhesive: IB Rapid Set ECO₂ Spray Foam, Millennium PG-1 EF ECO₂ Adhesive.
³The use of some IB Approved Low Rise Membrane Adhesives may not achieve UL Classification.
System Uplift Note(s): **Refer to applicable Approval Guide for System Code and/or FM Approvals Information. *Refer to Substrate Resistance Table for required pull-out values.**
 For additional information about IB Roof Systems requirements, recommendations, installation details, approvals, and limitations for the above assemblies, please refer to the latest edition of the IB Roof Systems Specifications Manual. For Technical Services please contact IB Technical Department at 800-426-1626.

Membranes:		Membrane Color:		Warranty Length**			Warranty Type**	
IB TPO FB 115 Mil		White*		10 Year	15 Year	20 Year	Contractor Warranty Only	
IB TPO FB 135 Mil		White*		10 Year	15 Year	20 Year	Total Systems - No Dollar Limit (TSW)	
*Meets CRRC, Title 24, LEED (SRI)				**Refer to Warranty Selection Guide for Warranty Riders, Term Length Limitations, and eligibility requirements of the IB Warranty Program			Warranty Plus (WP)	
							Commercial Limited Material Warranty (CLMW)	
							Residential Limited Material Warranty (RLMW)	

Submitted By:		Project Name:	
Company Name:		Address:	
Email/Phone:		City/State:	