

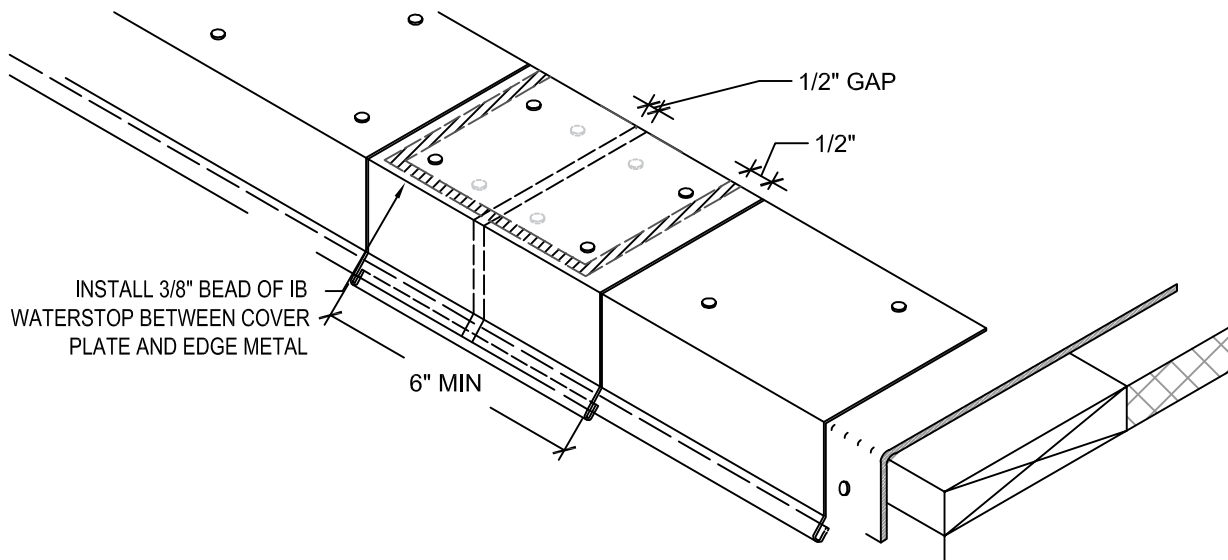

Perimeter Edge

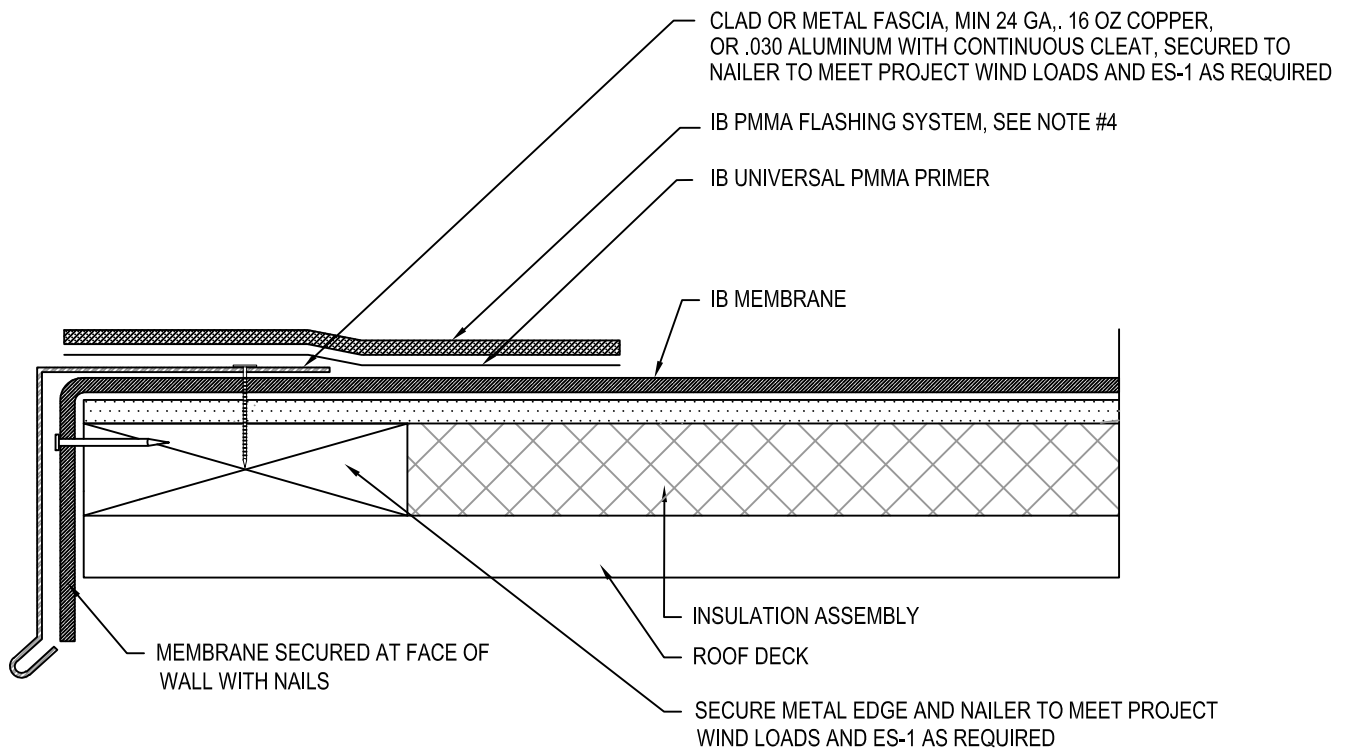

Notes:

1. EDGE METAL TO BE FASTENED WITH CORRESPONDING NAILS AT 4" O.C. STAGGERED.
2. CLEAN AND WIPE METAL EDGING PRIOR TO INSTALLATION.
3. SECURE FLASHING AND METAL WORK IN ACCORDANCE WITH IB SPECIFICATIONS AND FLASHING SECUREMENT TABLE.
4. REFER TO PM-FD-02 FOR TWO-PLY PMMA FLASHING APPLICATION FOR EXTENDED WARRANTY.
5. NON-CLAD METAL IS NOT ELIGIBLE FOR COVERAGE IN IB TOTAL SYSTEMS WARRANTY.

Scale: NTS	Detail Name: Drip Edge with PMMA Flashing	Detail Number: PM-PE-01
Submitted By: Address: Telephone:		Project: Address: